



# COOLING SYSTEM PRESSURE TEST KIT 4PC

MODEL NO: VS0012

Thank you for purchasing a Sealey product. Manufactured to a high standard, this product will, if used according to these instructions, and properly maintained, give you years of trouble free performance.

**IMPORTANT:** PLEASE READ THESE INSTRUCTIONS CAREFULLY. NOTE THE SAFE OPERATIONAL REQUIREMENTS, WARNINGS & CAUTIONS. USE THE PRODUCT CORRECTLY AND WITH CARE FOR THE PURPOSE FOR WHICH IT IS INTENDED. FAILURE TO DO SO MAY CAUSE DAMAGE AND/OR PERSONAL INJURY AND WILL INVALIDATE THE WARRANTY. KEEP THESE INSTRUCTIONS SAFE FOR FUTURE USE.



Refer to instructions



Wear eye protection



Wear protective gloves



Hot surfaces

## 1. SAFETY

- ❑ **WARNING!** Ensure all Health & Safety, local authority, and general workshop practice regulations are strictly adhered to when using this product.
  - ❑ **WARNING!** Ensure the engine and cooling system has cooled, before opening the radiator cap.
  - ✓ Maintain tools in good and clean condition for best and safest performance. **DO NOT** use tester if damaged.
  - ✓ Wear suitable clothing to avoid snagging. **DO NOT** wear jewellery and tie back long hair.
  - ✓ Wear approved eye protection. A full range of personal safety equipment is available from your Sealey stockist.
  - ✓ Keep yourself, tools, and test equipment away from hot engine parts.
  - \* **DO NOT** use this tool for any purpose other than that for which it is designed.
  - \* Never lay tools on the vehicle's battery. This may short the terminals together, causing harm to yourself, the tools, or the battery.
  - ✓ Account for all tools and parts being used and **DO NOT** leave any in the engine bay.
  - ✓ Keep children and other unauthorised persons away from the working area.
  - ✓ Keep test kit parts clean, store parts in the carry case, and keep this in a safe, dry, childproof location.
  - \* **DO NOT** run engine while pressure testing.
  - \* **DO NOT** use in radiators or header tanks with internal neck diameters greater than 45mm.
- IMPORTANT:** Always refer to the vehicle manufacturer's service instructions, or a proprietary manual to establish the current procedure and data. These instructions are provided as a guide only.

## 2. INTRODUCTION

- Capless cooling system tester uses an inflatable bladder to seal the coolant header tank or radiator.
- Bladder system can be used on both screw and bayonet fittings and seals 90% of cars and light commercial vehicles straight out of the box
- Supplied with two adaptors, enabling testing of VAG vehicles with internal threads on header tank.
- Features quick-release couplings, easy-to-read pressure gauge and release valve.

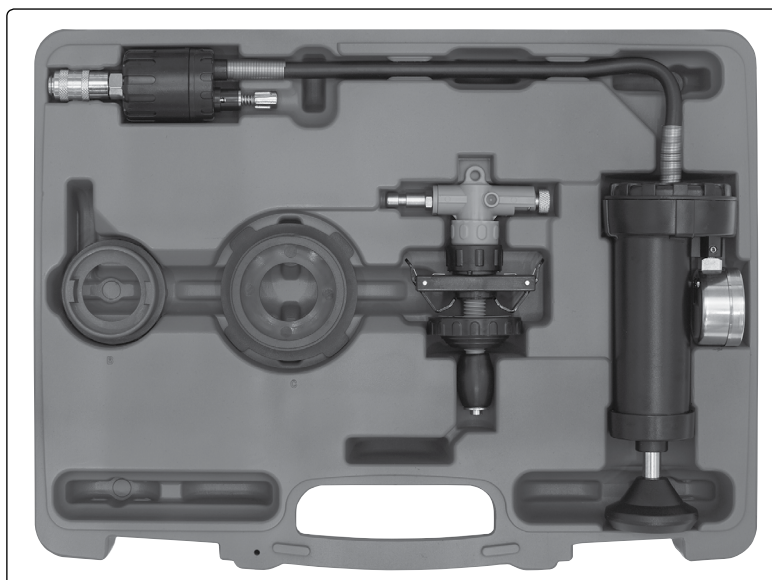

### 3. OPERATION

#### 3.1. Prior to testing

- 3.1.1. Make sure you have read warnings before use.
- 3.1.2. Remove radiator pressure cap and check condition.
- 3.1.3. Inspect filler neck for any sharp obtrusions that may damage the bladder and remove if necessary.
- 3.1.4. Check coolant level and top up if required.
- 3.1.5. To ensure secure fitting and positive sealing it is desirable that two thirds of the bladder (fig.1.3) is below the lower flange on the radiator or header tank neck before being inflated.

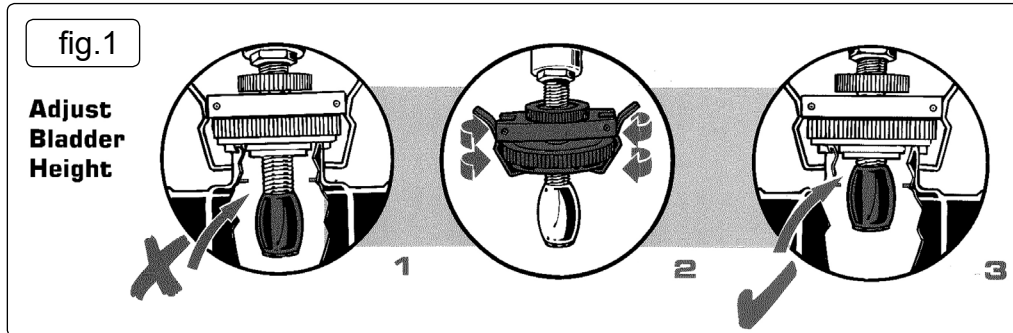

**Note:** It may not always be possible to adjust the bladder the desirable position (two thirds of the bladder below lower flange). The flexible nature of the inflatable bladder will create the required seal in these applications.

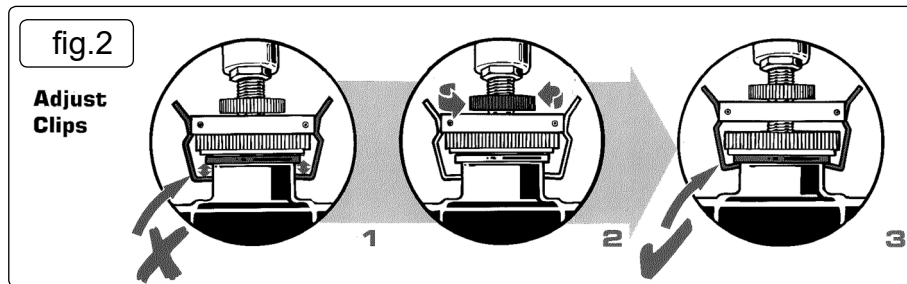
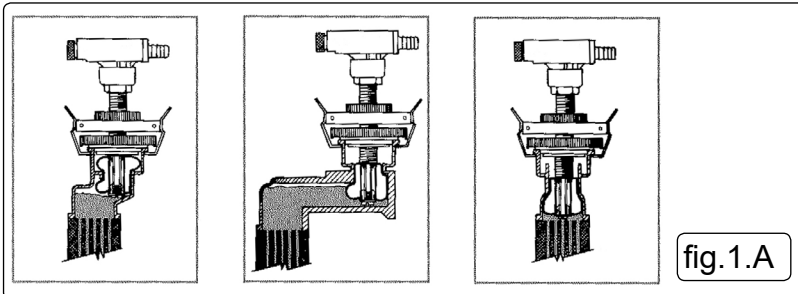

#### 3.2. Pressure Testing

- **WARNING:** DO NOT run engine while pressure testing.

**Note:** If testing is being carried out on a warm engine a pressure drop may occur due to engine cool down, which may not be due to a leak. Pressurise and inspect again after cool down is complete.

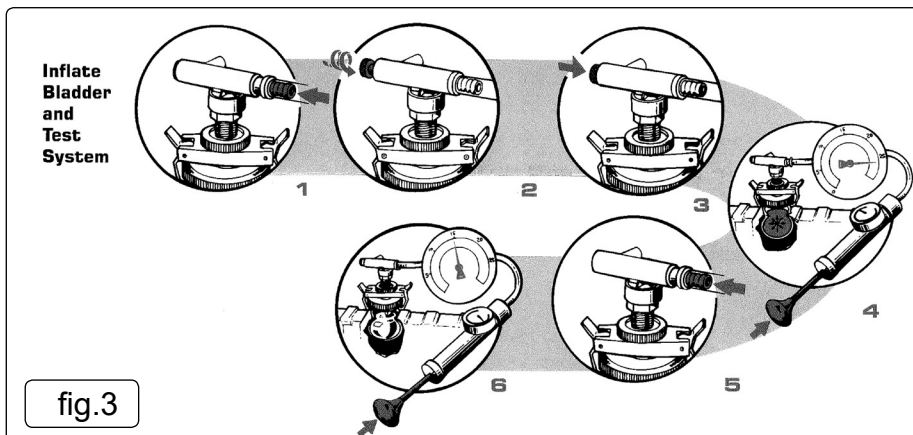

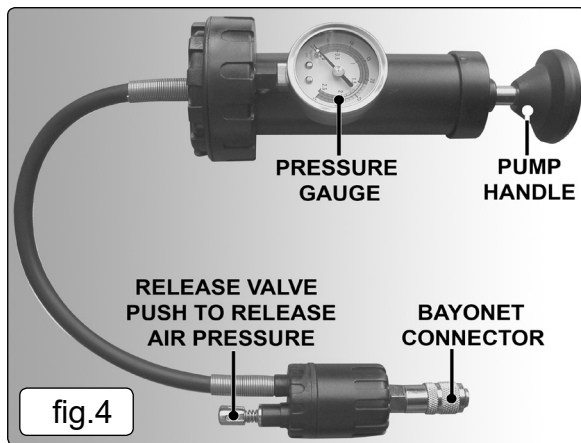

- 3.2.1. Move slide valve so that brass bleed screw is exposed (fig.3.1).
- 3.2.2. Adjust pressure bleed screw clockwise until firm - **DO NOT** over tighten (fig.3.2).
- 3.2.3. Press the brass bleed screw until the valve slides across (fig.3.3).
- 3.2.4. Operate hand pump to inflate bladder to 15 psi (**DO NOT** exceed this pressure) (fig.3.4)  
**NOTE: Due to the design of the internal pump seal, a vigorous pumping action is required to activate the seal and pressurise the system. A light or slow pumping action will prove ineffective. The larger the air space within the cooling system being tested, the more vigorous the initial pumping should be. By filling the cooling system and therefore reducing the airspace within, less effort will be needed to pressurise it.**
- 3.2.5. Move slide valve so brass bleed screw is exposed (fig 3.5)
- 3.2.6. Operate hand pump to pressurise system to manufacturers specified pressure - **DO NOT** exceed this pressure as system damage may occur (fig.3.6).
  - If system pressure is maintained no serious leaks are present.
  - A pressure drop indicates a system leak.
  - Continued pressure drop, visually inspect for external leaks.
- 3.3. **Removal from System**
  - **WARNING: DO NOT** deflate bladder until gauge read '0' psi To release pressure from the pump, press the release valve (fig.4). Ensure the gauge is reading zero to indicate no pressure before disconnecting

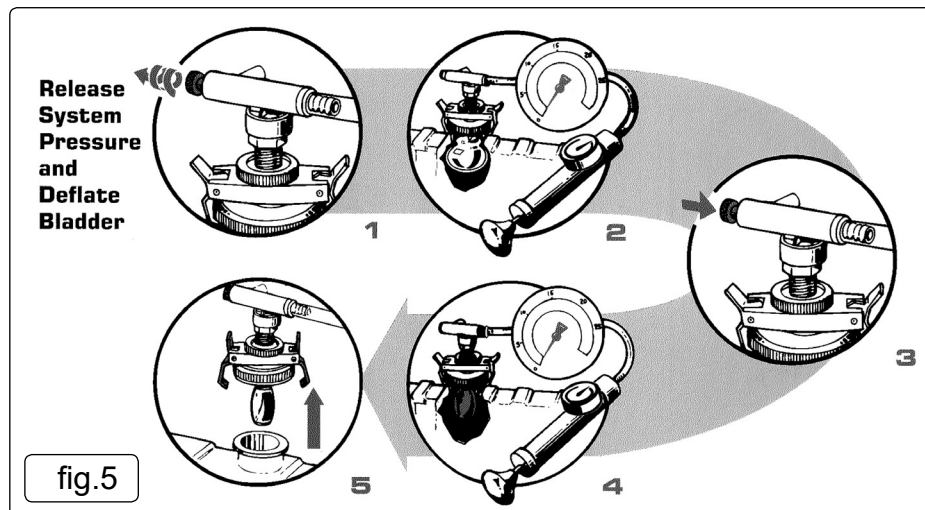

- 3.3.1. Adjust pressure bleed screw anti-clockwise (fig 5.1).
- 3.3.2. Allow pressure to release via drain hose until gauge reads '0' psi (fig.5.2).
- 3.3.3. Press on brass bleed screw until valve slides across (fig.5.3).
- 3.3.4. The bladder is now deflated (fig.5.4).
- 3.3.5. Release retaining clips and remove (fig.5.5).

## 4. MAINTENANCE

- 4.1. This unit is a testing instrument and should be treated accordingly. Keep unit clean by rinsing with water after each use to prevent internal components sticking.  
**Note: DO NOT** use harsh chemicals or solvents.
- 4.2. The rubber bladder and safety seal will wear with normal use. Replace bladder or safety seal if any deterioration is noted.
- 4.3. **Bladder Replacement:**
  - 4.3.1. Remove centre tube mounting screw from base of centre tube.
  - 4.3.2. Remove centre tube flange.
  - 4.3.3. Remove bladder from stem.
  - 4.3.4. Install new bladder onto stem using a twisting action (use water as a lubricant if required - **DO NOT** use grease or other lubricants).
  - 4.3.5. Install centre tube flange.
  - 4.3.6. Install centre tube mounting screw with 'O'- ring and tighten fully. Note: **DO NOT** over tension.
  - 4.3.7. Inflate bladder to three or four times to condition and stretch material.
  - 4.3.8. With bladder inflated, immerse in water to test for leaks.

## 5. TROUBLESHOOTING

### 5.1. Pressure Drop on Bladder Circuit

- 5.1.1. Check mounting of bladder to sleeve, centre tube flange and stem.
- 5.1.2. Check tension of centre tube mounting screw.
- 5.1.3. Check one-way pressure valve for leakage. Mounted in hand pressure pump. Use genuine replacement parts only.
- 5.1.4. Check condition of pressure bleed screw and seat.
- 5.1.5. Check condition of side valve 'O'-rings.

### 5.2. Pressure Drop on System Circuit

- 5.2.1. First confirm the pressure drop is not due to a leak in the cooling system.
- 5.2.2. Check bladder size is adequate to seal tank neck. Condition bladder by inflating to 15psi three or four times off vehicle if required.
- 5.2.3. Ensure correct adjustment of unit as per instructions (fig.2)
- 5.2.4. Check one-way pressure valve for leakage. Mounted in pressure pump.
- 5.2.5. Check condition of pressure bleed screw and seat.
- 5.2.6. Check condition of slide valve 'O'-rings.



#### ENVIRONMENT PROTECTION

Recycle unwanted materials instead of disposing of them as waste. All tools, accessories and packaging should be sorted, taken to a recycling centre and disposed of in a manner which is compatible with the environment. When the product becomes completely unserviceable and requires disposal, drain any fluids (if applicable) into approved containers and dispose of the product and fluids according to local regulations.

**Note:** It is our policy to continually improve products and as such we reserve the right to alter data, specifications and component parts without prior notice.

**Important:** No Liability is accepted for incorrect use of this product.

**Warranty:** Guarantee is 12 months from purchase date, proof of which is required for any claim.

Sealey Group, Kempson Way, Suffolk Business Park, Bury St Edmunds, Suffolk. IP32 7AR



01284 757500



01284 703534



sales@sealey.co.uk



www.sealey.co.uk