

Thank you for purchasing a Sealey product. Manufactured to a high standard this product will, if used according to these instructions and properly maintained, give you years of trouble free performance.



IMPORTANT: PLEASE READ THESE INSTRUCTIONS CAREFULLY. NOTE THE SAFE OPERATIONAL REQUIREMENTS, WARNINGS & CAUTIONS. USE THE PRODUCT CORRECTLY AND WITH CARE FOR THE PURPOSE FOR WHICH IT IS INTENDED. FAILURE TO DO SO MAY CAUSE DAMAGE AND/OR PERSONAL INJURY, AND WILL INVALIDATE THE WARRANTY. PLEASE KEEP INSTRUCTIONS SAFE FOR FUTURE USE.

1. SAFETY INSTRUCTIONS

1.1 GENERAL SAFETY

- ❑ **WARNING!** Ensure Health & Safety, local authority, and general workshop practice regulations are adhered to when using this cabinet.
- ❑ **WARNING!** Use caution when handling and assembling the metal components. The metal may have sharp edges or corners, the use of protective gloves is recommended.
- ✓ Locate cabinet in a suitable working area and secure to a wall with suitable fasteners.
- ✓ Keep the work area clean and uncluttered.
- ✓ Keep the cabinet clean and tidy in accordance with good workshop practice.
- ✓ Keep children and unauthorised persons away from the working area.
- x **DO NOT** climb, step or stand on the cabinet shelves.
- x **DO NOT** use the cabinet for any purpose other than that for which it is designed.
- x **DO NOT** use in damp work areas.
- ❑ **WARNING!** The warnings, cautions and instructions referred to in this instruction manual cannot cover all possible conditions and situations that may occur. It must be understood that common sense and caution are factors which cannot be built into this product, but must be applied by the operator.

2. INTRODUCTION

Use as an individual storage unit. Featuring two large doors, four shelves and base storage. Added security provided by cylinder lock, supplied with two keys. All steel construction, stabilised by an inner cross member. Supplied flat packed to save freight cost, simple assembly required.

Size (W x D x H): 916 x 458 x 1830mm

3. CONTENTS

3.1 CONTENTS INSPECTION

Unpack all the parts and layout on the packing material.

A1	Back (left hand side).....	1 off
A2	Back (right hand side).....	1 off
B1	Side (left hand side).....	1 off
B2	Side (right hand side).....	1 off
C	Cross member	1 off
D	Base	1 off
E	Base outer fascia	1 off
F	Top	1 off
G	Short Shelf	3 off
H1	Door (left hand side)	1 off
H2	Door (right hand side).....	1 off
I	Bolt and butterfly nut.....	4 off
J	Top panel retainer moulding	2 off
K	Hinge pivot moulding	4 off
L	Locking rod recess moulding	2 off
M	Central divider.....	1 off
N	Full width shelf	1 off
O	Coat rail fixing	2 off
P	Coat rail.....	1 off
Q	Door stop moulding.....	4 off
R	Hinge pin.....	4 off
S	Shelf stop	12 off

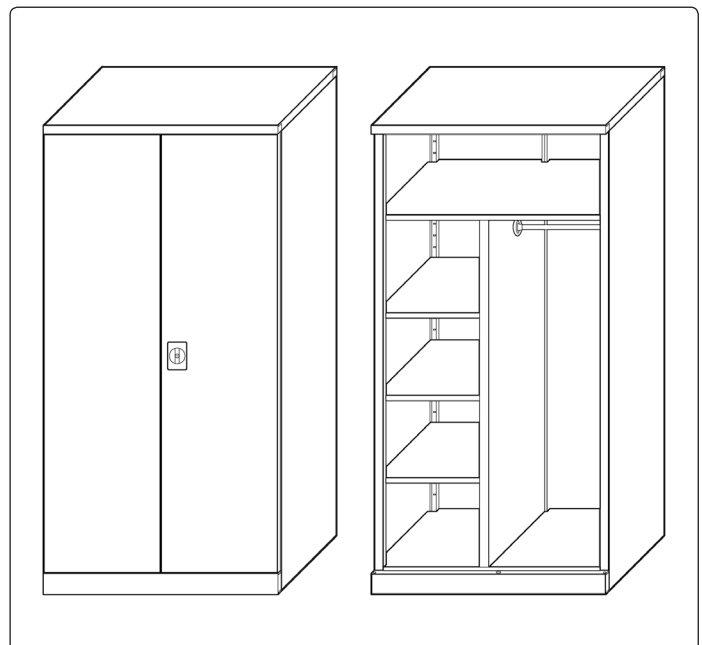
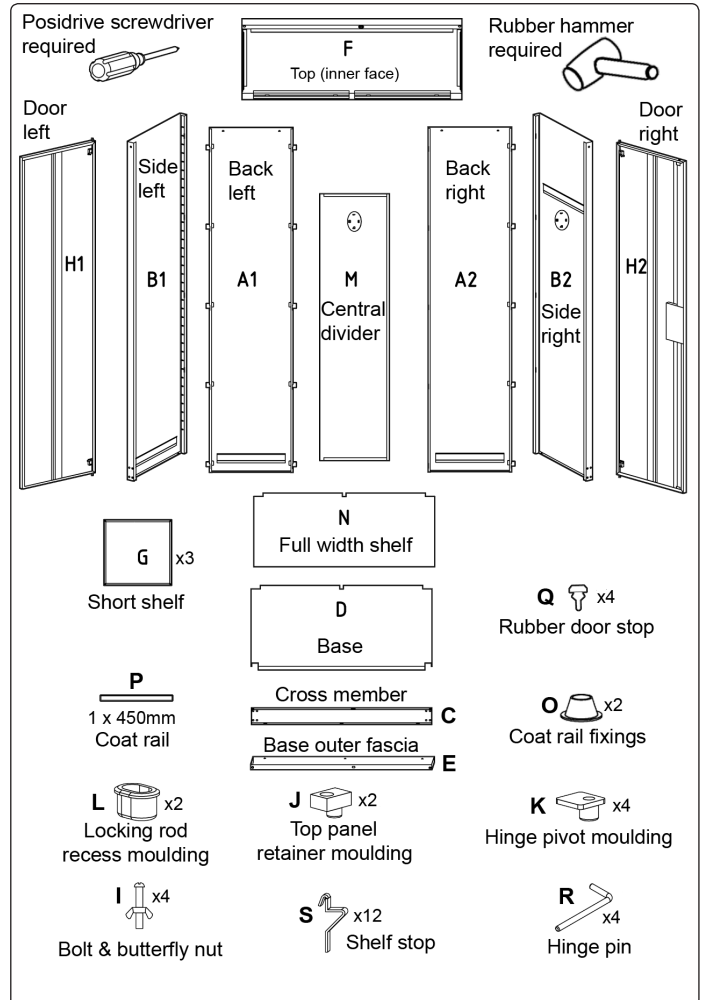

4. ASSEMBLY

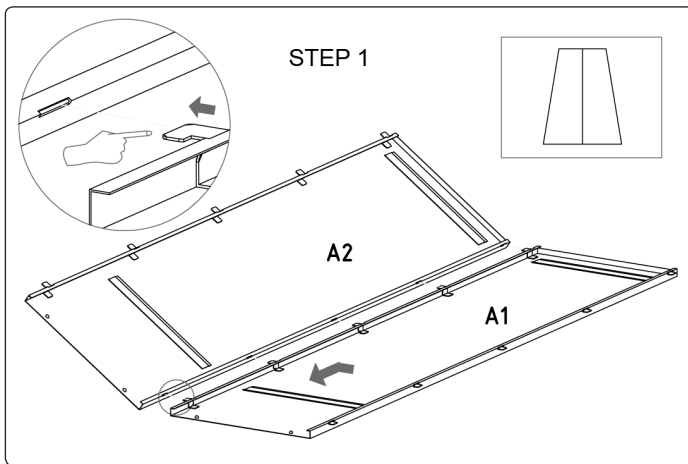

4.1 BACK ASSEMBLY (Step 1)

- 4.1.1 Place the back panels (A1 & A2) on a suitably protected flat surface to prevent scratching.
- 4.1.2 Interlock the tabs into the slots on the back panels and slide together until the two panels are fully engaged and aligned.

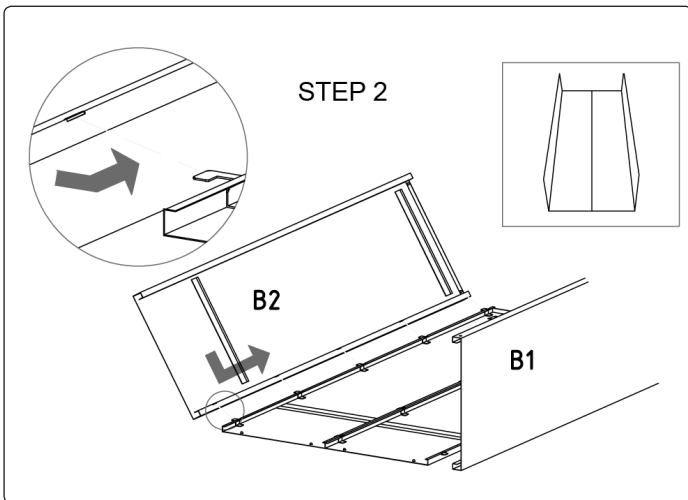

4.2 SIDE ASSEMBLY (Step 2)

- 4.2.1 Hold the side panels (B1 & B2) at a slight angle and fit the tabs on the back panels into the slots of the side panels and slide up to engage.

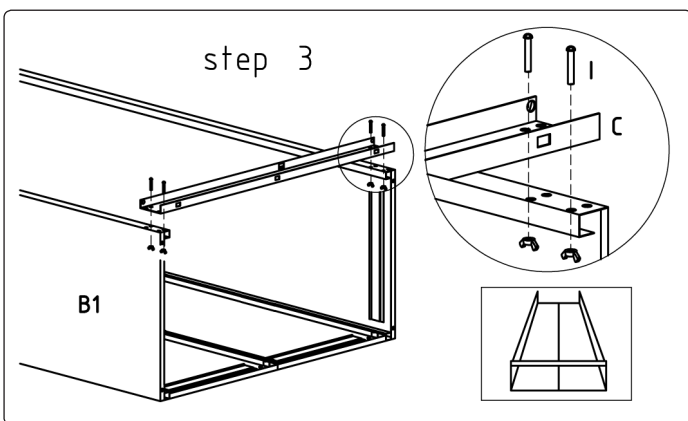

4.3 CROSS MEMBER ASSEMBLY (Step 3)

- 4.3.1 Tie the side panels together at the bottom front edge by attaching the cross member (C) using four bolts (I) and four butterfly nuts as shown in the inset diagram above.

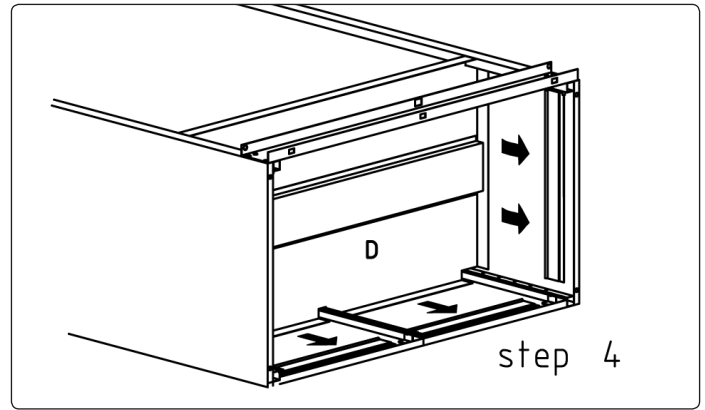

4.4 BASE ASSEMBLY (Step 4)

- 4.4.1 Place the base (D) into position as shown above and slide it down to the bottom until its edges make contact with the receiving channels on the back and side panels. Using a rubber hammer, tap the base down until it is fully engaged in the channels.

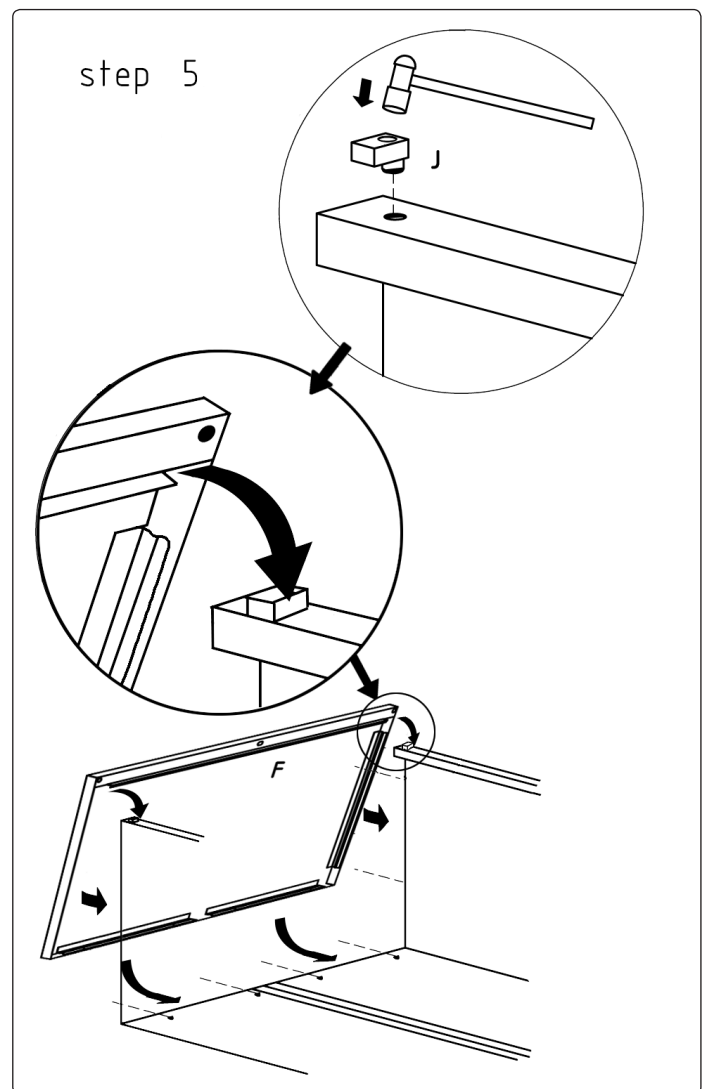

4.5 TOP ASSEMBLY (Step 5)

- 4.5.1 Take the two top panel retainer mouldings (J) and fully insert one into each hole at the top front edge of each side panel in the orientation shown in Step 5.
- 4.5.2 Take the top panel (F) and hook its front edge over the two retainer mouldings, then swing the panel downwards until the top edges of the back and side panels begin to enter the receiving channels within the top panel. Tap the top panel down into position using a rubber hammer until the four indents in the back panels clip into the matching holes in the back receiving channels.

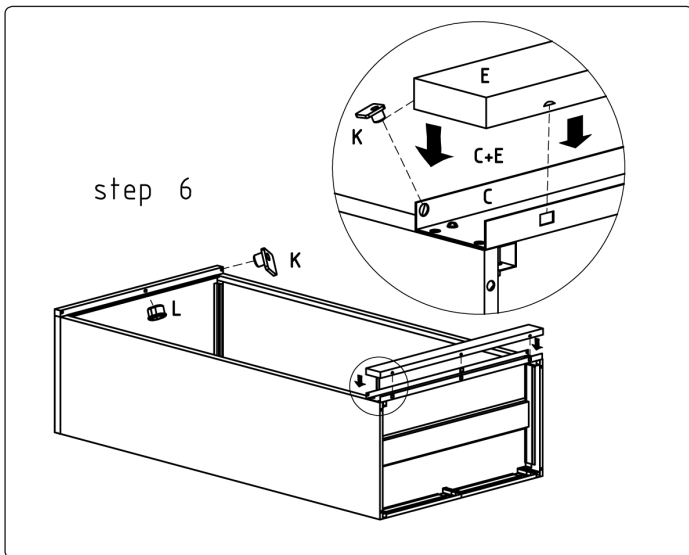

4.6 BASE OUTER FASCIA ASSEMBLY (Step 6)

- 4.6.1 Fit the base outer fascia (E) over the cross member (C) with the hinge pivot holes facing upwards. Tap the base outer fascia down with a rubber hammer until the indents in the sides of the fascia clip into the matching holes on the cross member (C).
- 4.6.2 Insert a hinge pivot moulding (K) at each end of the upper face of the base outer fascia (E). Insert the other two hinge pivot mouldings at each end of the downward facing edge of the cabinet top.
- 4.6.3 Insert a locking rod recess moulding (L) into the centrally placed holes in the same faces used for mounting the hinge pivot mouldings at both the top and the bottom.

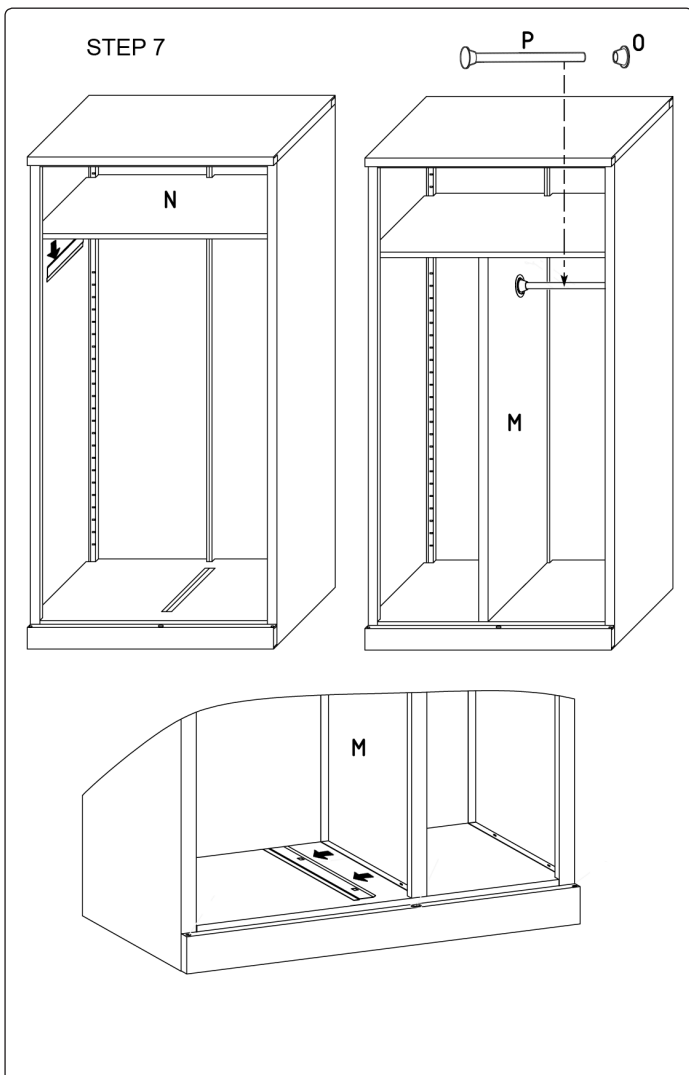

4.7 INTERNAL DIVIDERS ASSEMBLY (Step 7)

- 4.7.1 Manoeuvre the Full width shelf (N) into the top of the cabinet, then move it downwards until the edges of the shelf begin to enter the receiving channels on the inside faces of the back and sides. Using a rubber hammer, tap down the shelf until it is fully engaged.
- 4.7.2 Position the divider panel (M) inside the cabinet, just to the right of the receiving channels on the base and on the underside of the full width shelf (N). Move the divider panel to the left until its edges begin to enter the receiving channels. Using a rubber hammer, tap the divider into place so that it is fully engaged.
- 4.7.3 Take the coat rail (P) and position a fixing (O) on either end. Slide the assembly into the right hand compartment of the cabinet and slide each fixing down into the 'U' shaped channels provided.

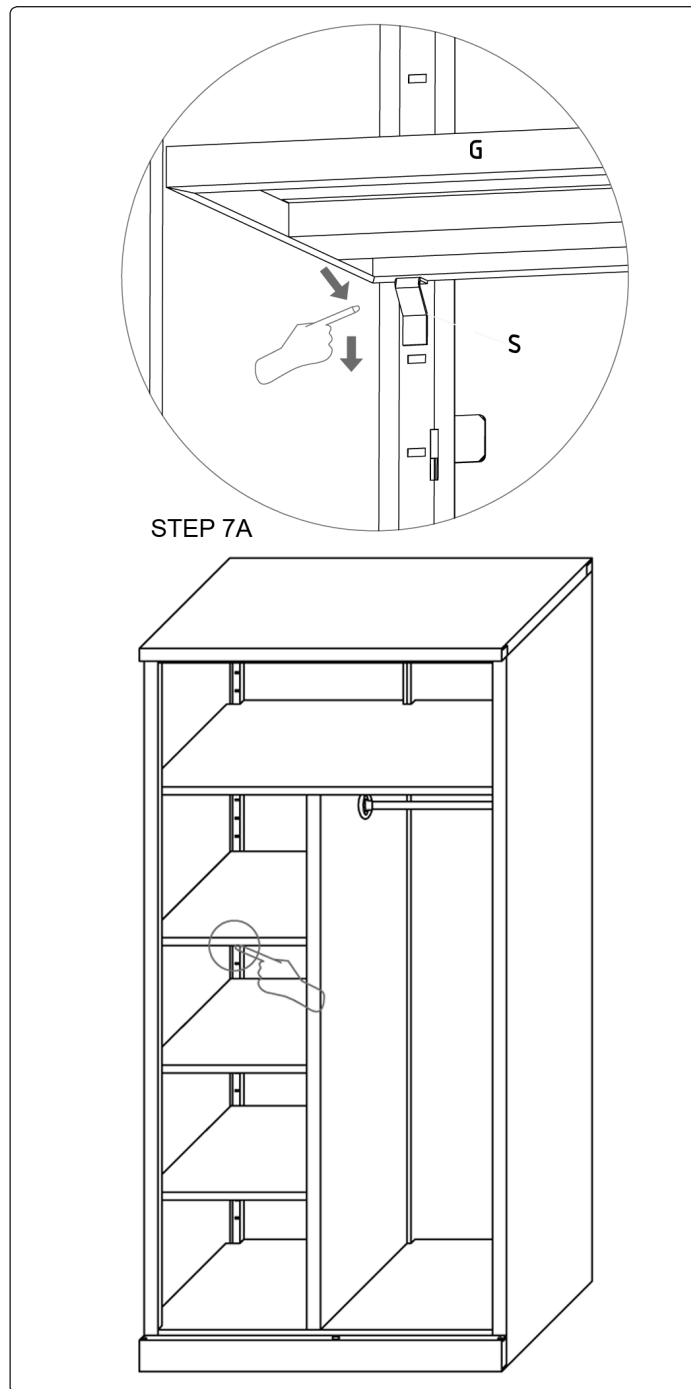

4.8 SHELF ASSEMBLY (Step 7A)

- 4.8.1 Insert shelf stops (S) at the desired height for each shelf and lay the shelves (G) onto the stops.

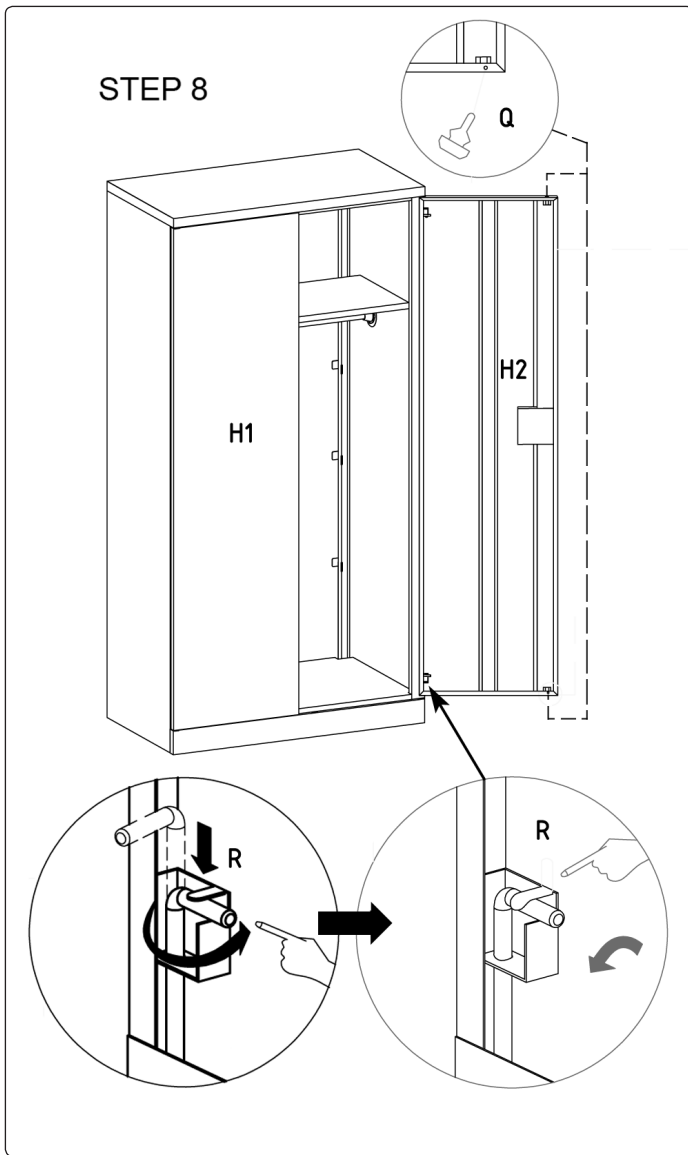

4.9 DOORS ASSEMBLY (Step 8)

4.9.1 Mount each door in turn by placing it between the upper and lower hinge pivot mouldings. Align the upper hole in the door edge with the hole in the upper pivot moulding and insert a hinge pin upwards through the door and into the moulding. Rotate the short arm of the pin around onto the inner face of the door as shown above and bend over the metal tab to retain it. Mount the lower hinge pin in the same way. Repeat the process to mount the other door.

4.9.2 Fit the rubber door stops (Q) as shown in Step 8 to the corners of each door

4.10 Using a mild solution of detergent and water and wipe the unit down with a soft cloth.

Parts support is available for this product. To obtain a parts listing and/or diagram, please log on to www.sealey.co.uk, email sales@sealey.co.uk or phone 01284 757500.

NOTE: It is our policy to continually improve products and as such we reserve the right to alter data, specifications and component parts without prior notice.

IMPORTANT: No liability is accepted for incorrect use of this product.

WARRANTY: Guarantee is 12 months from purchase date, proof of which will be required for any claim.

INFORMATION: For a copy of our latest catalogue and promotions call us on 01284 757525 and leave your full name and address, including postcode.



Sole UK Distributor, Sealey Group,
Kempson Way, Suffolk Business Park,
Bury St. Edmunds, Suffolk,
IP32 7AR

01284 757500

01284 703534



www.sealey.co.uk



sales@sealey.co.uk