



RECOVERY WINCH 12V INDUSTRIAL

MODEL NO: **RW8180**

Thank you for purchasing a Sealey product. Manufactured to a high standard, this product will, if used according to these instructions, and properly maintained, give you years of trouble free performance.

IMPORTANT: PLEASE READ THESE INSTRUCTIONS CAREFULLY. NOTE THE SAFE OPERATIONAL REQUIREMENTS, WARNINGS & CAUTIONS. USE THE PRODUCT CORRECTLY AND WITH CARE FOR THE PURPOSE FOR WHICH IT IS INTENDED. FAILURE TO DO SO MAY CAUSE DAMAGE AND/OR PERSONAL INJURY AND WILL INVALIDATE THE WARRANTY. KEEP THESE INSTRUCTIONS SAFE FOR FUTURE USE.



Refer to instructions



Wear eye protection



Wear protective gloves

1. SAFETY

- WARNING! Winching a vehicle, especially with a steel cable, has an inherent danger element to it, and there is always some risk of injury. Proper training is highly advised and constant risk assessment needs to be undertaken.**
 - WARNING! Never connect DC powered winches to AC current. Motor damage or fatal shock may occur.**
 - * **DO NOT** lift or hoist loads over people. **DO NOT** lift loads vertically. The winch was designed for ground use only.
 - * **DO NOT** overload. Be sure all equipment used meets the winch's maximum line pull rating. We recommend using the pulley block option to double line the wire rope (see fig.1). Double line with a pulley block to reduce the load on the winch, wire rope and battery. When double lining, pulley blocks should be rated to a minimum of two times the winch's line pull rating. The cable may break before the winch stalls. For heavy loads use a pulley block to reduce the load on the cable.
 - * **DO NOT** immerse the winch in water. Doing so will immediately effect load holding and brake efficiency and in time will damage the motor and cause accelerated gearbox wear invalidating the warranty.
 - * **DO NOT** operate the winch with less than 5 turns of wire rope around the winch drum, since the wire rope end may not withstand the full load.
 - * **DO NOT** pull from extreme angles, (see fig.2), because this will cause the rope to build up on one end of the drum, this will break the tie bars from the castings, will damage the wire rope, and invalidate the warranty.
 - WARNING!** The winch's line pull capacity is the maximum line pull of the first layer. Never operate a winch by pulling a load that is at or over the rated capacity.
 - * **DO NOT** hook the wire cable back to itself because it could damage the wire rope. Use a Self Recovery Kit, (see fig.3) contact your dealer for full details.
 - * Make sure the winch is securely mounted on the vehicle or bracket before operation.
 - * Before moving a load inspect the wire rope. Prevent kinks and uneven wire layering before they occur. Loosened wire rope must be properly tensioned under a load of about 100lbs (45.4kg).
 - * Position a Wire Rope Dampener (available as an optional extra) over the wire rope near the hook end when pulling, as this will slow the snap back of a broken wire rope and reduce/prevent serious injury and/or damage.
 - * **DO NOT** move your vehicle to assist the winch in pulling the load. It will be easy to overload, and cause wire rope damage.
 - * **DO NOT** enter the danger zone. Keep away from the danger zone during operation. The danger zone is the area of the winch drum, the fairlead (if fitted), the wire rope, the pulley block (if used), and the hook.
 - * **DO NOT** approach or span the wire rope when the winch is under load.
 - * When using the winch to move a load, place the vehicle transmission in neutral, apply the handbrake and chock all wheels. The vehicle engine should be running during winch operation so that the battery is fully charged. Never use the winch if there is any doubt as to the efficiency of the battery.
 - * **DO NOT** disconnect the free spool clutch when there is load on the winch.
 - * After operation release the load immediately. **DO NOT** allow the cable to tighten anymore.
 - * Inspect winch, wire rope, hooks and other accessories frequently. A mashed, pinched, kinked or frayed wire rope with broken strands should be replaced at once because a damaged wire rope has a reduced load carrying capability and could break easily.
 - * Keep tension on the cable to re-spool the cable on the drum tightly after operating. It must be re-spooled with a load of about 45.4kg (100lbs).
 - * **DO NOT** allow the wire rope to slide through your hands, use heavy rigger gloves when handling wire rope.
 - * Disconnect the clutch first then use the hand saver strap to hitch the hook and pull the wire rope. **DO NOT** pull the wire rope using your finger and **DO NOT** put your finger through the hook.
 - * **DO NOT** operate the winch when under the influence of drugs, alcohol or medication.
 - * If there is something wrong with the winch, cut the power at once, then check it carefully. If required, return it to your dealer for servicing.
 - * Wear eye protection, insulated work clothes, non-slip shoes, keep hair tied up and wear rigger gloves. Remove all jewellery.
 - * **DO NOT** machine or alter the winch in any way.
 - * Take good care of the winch when not in use.
 - WARNING!** Unplug the remote control before working in or around the fairlead or the wire rope drum, (the danger zone). Never tuck it under your arm or allow anyone to hold it when you are in the danger zone, so as to avoid the hand control being accidentally activated.
 - WARNING! DO NOT** use the winch to hold loads in place. Use other means of holding loads such as tie down straps.
 - WARNING!** If you are within four feet of the winch do not hold the wire rope and remote control at the same time.
 - WARNING!** Mount the winch to a firm base. Be sure that your structural support is strong enough to withstand the weight and rated pulling strength of the winch.
- NOTE:** Whilst mounting orientation is at your discretion, the winch is to be operated with the wire rope in an under wound orientation on the drum. The winch is designed to rope out and rope in, in one direction. **DO NOT** attempt to reverse the operation of the winch.

- ❑ **WARNING! DO NOT** weld or machine any part of the winch, this will weaken it and void the warranty.
 - ❑ **WARNING!** Batteries contain explosive gases. The following precautions should be taken before making battery connections: wear eye protection; remove all jewellery; follow the wiring diagram included in the installation instructions; keep spectators away. In the event of a battery explosion, acid should be washed away as soon as possible, seek medical help immediately.
 - ❑ **WARNING!** Use of any other accessories or attachments other than those recommended in this instruction manual may result in personal injury or property damage and could void the warranty.
- NOTE:** The safety precautions and instructions discussed in this manual can't cover all possible conditions and situations that may occur. It must be understood by the operator that common sense and caution are factors which cannot be built into this product but must be applied by the operator.

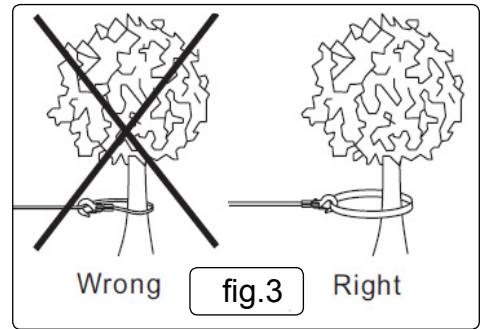
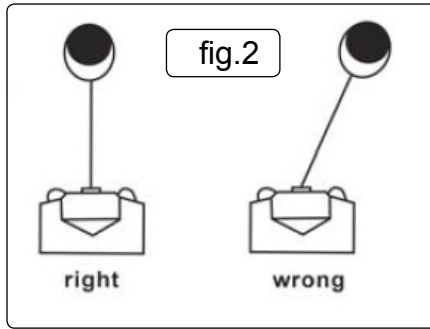
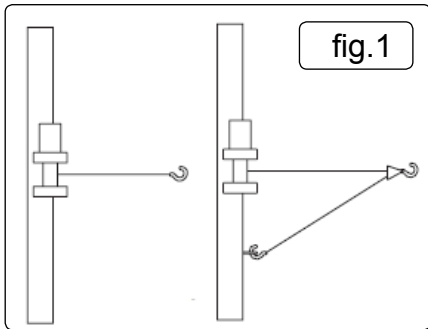

2. INTRODUCTION

These industrial recovery winches are designed and built for breakdown recovery and off-road use. Heavy-duty motors with 4-stage planetary gears using oversized components for greater torque, plus automatic 'in drum' brake. Both models have weather sealed solenoids and ergonomic 'lift & turn' free spool clutches. Both are supplied with wire rope, latched hook, 4-way roller fairlead and plug-in handheld controller as standard. Ideal for flat bed pick up or other recovery trucks.

3. SPECIFICATION

Model No:..... RW8180
 Voltage:..... 12V
 Line Pull*:..... 8180kg
 Motor Power:..... 2.3kW
 Gear Ratio:..... 516:1
 Line Speed*:
 No Load: 3.5mtr/min
 At Maximum Load: 0.8mtr/min
 Current Draw:
 No Load: 95A
 At Maximum Load: 420A
 Cable Ø:..... 13mm
 Cable Length:..... 25mtr
 Winch Weight: 74kg
 Gross Weight: 79kg
 Replacement Wire Rope: RW8180.WR

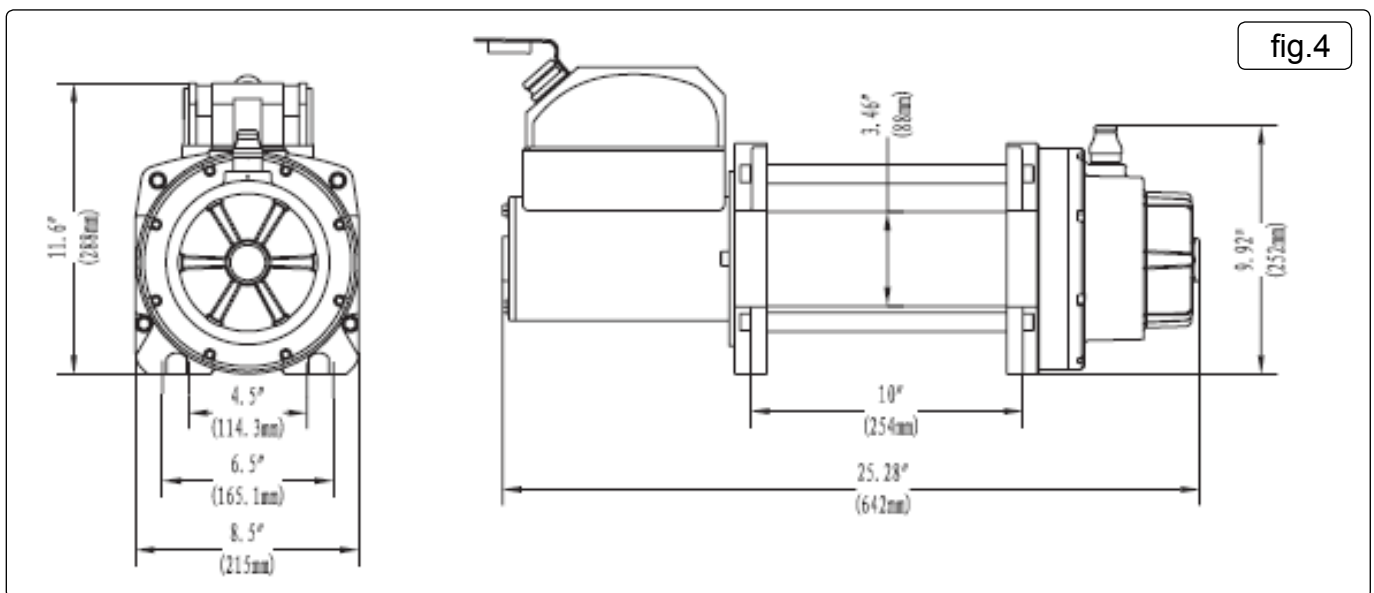

Chart 1.

Single Line rated pull	8180kg
Gear reduction ratio	516.1
Motor	2.3kw
(Series wound)	3.1hp
Overall dimensions	642x215x288mm
Drum size	Ø88x224mm
Cable length	Ø13mmx25m
Net weight	78.0kg

LINE PULL AND LINE SPEED vary according to how much cable is on the drum. The winch is rated at the first layer of cable on the drum. The maximum line pull force will be reduced by subsequent layers of cable on the drum. Chart 2 illustrates the maximum line force at increasing cable layers.

Chart 2.

8180 kg winch line pull and cable capacity

Layer of cable		1	2	3	4
Rated line pull per layer	lbs	18000	14313	11881	10155
	kg	8180	6498	5394	4610
Cable capacity per layer	Ft.	16.6	37.6	62.8	82
	m	5.1	11.5	19.1	25

Chart 3.

8180 lbs winch line speed and motor current (first layer)

Line pull	lbs	0	8000	14000	16000	18000
	kg	0	3632	6356	7264	8180
Line speed	(12V)FPM	11.5	5.6	3.9	3.3	2.6
	(12V)MPM	3.5	1.7	1.2	1.0	0.8
Motor current	(12V)Amps	95	260	380	400	420

* Use double line and block for pulling loads over 10,000lb / 4540kg.

4. INSTALLATION

4.1. WINCH INSTALLATION

- 4.1.1. The winch needs to be mounted onto a steel mounting using the 4 point foot mounting system, in either a horizontal or vertical plane.
- 4.1.2. The winch needs to be mounted on a flat surface so that the three sections (motor, cable drum and gear housing) are properly aligned.
- 4.1.3. Before installation ensure the mounting position being used is capable of withstanding the winch weight and the rated capacity.
- 4.1.4. Use the dimensions in fig.4 to manufacture a steel mounting plate, a minimum of 6mm thick. Fasteners should be high tensile steel, grade 5 or better. A poorly designed mount may invalidate the warranty.
- 4.1.5. The winch should be secured to the mounting with grade 8.8 M12 bolts and spring washers, see fig.5.

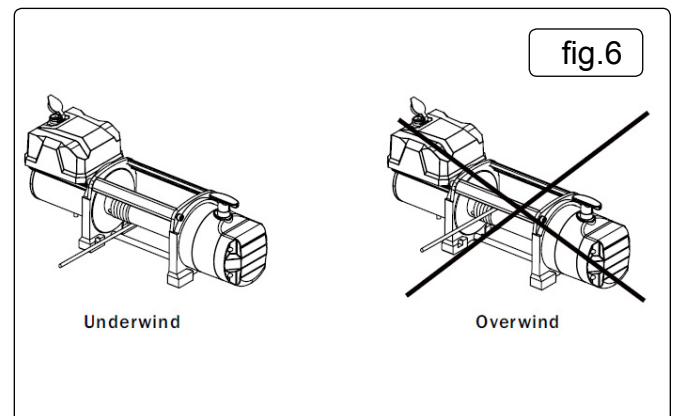
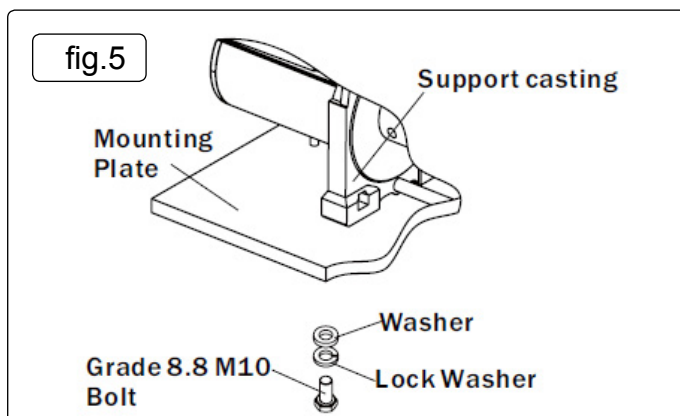

4.2. **ELECTRICAL INSTALLATION (Refer to fig.7)**

WARNING! This winch works on standard automotive 12V DC only, never connect this winch to a 230V mains as solenoid burnout or fatal shock may occur.

4.2.1. For normal self-recovery work, your existing electrical system is adequate. A fully charged battery and proper connections are essential. Run the vehicle engine during winch operation to keep the battery charged. Pay close attention to the electrical connections below, ensure that they are made correctly.

NOTE: For best performance a battery with 440 cold cranking ampere capacity and a 60 amp alternator are the minimum recommended power source. If the winch is in heavy use, an auxiliary battery and heavy duty alternator with isolator are recommended.

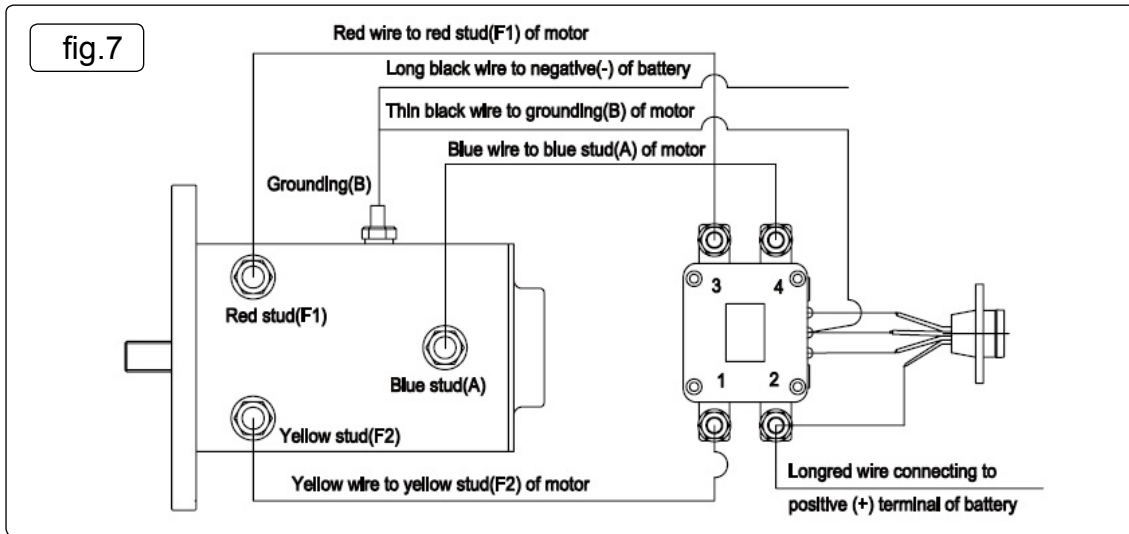

WARNING! Make sure the battery is disconnected.

- 4.2.2. Connect the red wire to the red stud (F1) of the motor and terminal 3 of the relay.
- 4.2.3. Connect the yellow wire to the yellow stud (F2) of the motor and terminal 1 of the relay.
- 4.2.4. Connect the blue wire to the blue stud (A) of the motor and terminal 4 of the relay.
- 4.2.5. Connect the thin black wire to the earth (B) of the motor.
- 4.2.6. Connect the long black wire to the motor earth (B) and the negative (-) terminal of the battery.
- 4.2.7. The long red wire will be connected to the positive (+) terminal of the battery and terminal 1 of the relay, but leave it disconnected from the battery for the time being.

NOTE: Your battery must be kept in good condition. Make sure the battery cables are not drawn across any surfaces which could possibly damage them. Corrosion on electrical connections will reduce performance or may cause a short circuit. Keep all connections clean especially in the remote control switch and receptacle. In salty environments use silicon sealer to protect from corrosion.

4.3. **ELECTRICAL LEAD WIRE ATTACHMENT**

- 4.3.1. Disconnect the battery.
- 4.3.2. The battery lead wires should be routed to the battery. To protect against abrasion apply several layers of electrical tape where wiring may come into contact with sharp metal parts of the vehicle.
- 4.3.3. All connections to motor, solenoids and battery earths require good, clean tight connections. Connect the red lead to the positive (+) terminal and the black lead to the negative (-) terminal of the battery.
- 4.3.4. The relay may be mounted remotely as space requires. If it is mounted more than 700mm (27") from the winch, use larger diameter wire.
- 4.3.5. Reconnect the battery, positive terminal first, then the negative. Rotate the clutch lever to the "disengaged position". Pull several metres of cable off the drum. Return the clutch lever back to the "engaged position". Plug in the remote switch assembly, refer to fig.9. Switch the hand control to "rope out" position. Pull the trigger momentarily to check cable drum rotation direction. If the drum rotates in the wrong direction, recheck the wiring.

WARNING! Double check the wiring. Incorrect wiring could result in motor burn out and/or personal injury.

5. OPERATION

WARNING! The switch assembly must be kept free of dirt and moisture to ensure safe operation.

5.1. The hand held switch activates power to the winch motor. To connect the remote control remove the waterproof plug cover and insert the control cable plug and turn the securing ring clockwise to lock see fig.9. The plug on the control cord is keyed and will only fit the socket one way. The switch trigger returns to the "Off" position when released. To change direction, press the rocker in the other direction, see fig.8.

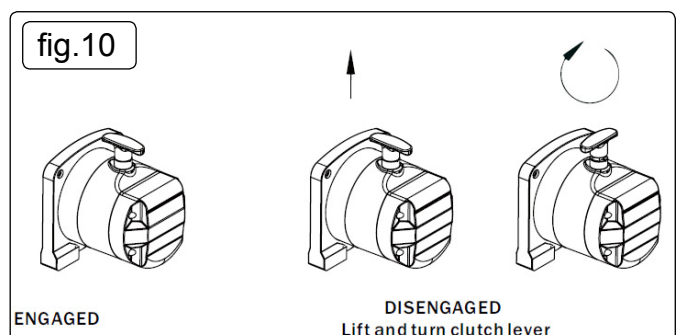
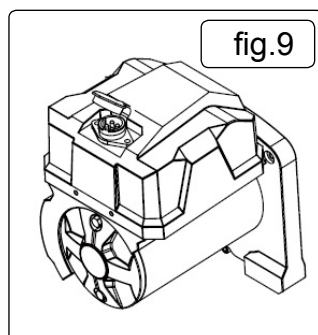

5.2. PULLING OUT THE WIRE ROPE

- 5.2.1. The wire rope has been installed on the winch under minimal load at the factory. It must be re-spooled onto the drum so the outer layers will not draw down into the inner layers, causing damage to the rope.
- 5.2.2. Pull and rotate the clutch lever to the, "disengaged" position as shown in fig.10. If there is a load on the wire rope, the clutch lever may not turn easily. **DO NOT** force the clutch lever. Release the tension on the wire rope by paying out some of the wire rope, then try releasing the clutch.
- 5.2.3. Pull out the wire rope and secure it to an anchor or a load.
- 5.2.4. Check that there are at least five turns of wire rope left on the drum.
- 5.2.5. Re-engage the drum by rotating the clutch lever to the "engaged" position, see fig.10.
- ☐ **WARNING!** The lever must be in the engaged position and locked before winching.
- 5.2.6. Your winch incorporates a proportional friction-type brake. After winching in a load, this mechanism holds the load, up to the rated capacity of the winch. While powering out the load, the winch controls the rate of speed by applying the brake in proportion to the amount of load on the wire rope. This results in heavier loads powering-out more slowly than lighter loads. Similar to the friction-type brakes in your car which can generate heat if used for a long time, the winch brake can generate heat if used to power-out a load for a long period of time. To ensure optimum winch performance, always limit powering-out a load to one minute and allow the brake to cool for fifteen minutes before continuing to winch. Under normal use the brake mechanism should not require any adjustment. Should the brake fail to hold a load or maintain a constant rate of speed during a powering-out operation, the brake pad may be worn and require replacement.
- 5.2.7. Keep a tightly wound wire rope drum. **DO NOT** allow the windings on the drum to become loosely wound. A loosely wound drum allows wire rope under load to work its way down into the layers of wire rope on the drum. When this occurs, wire rope may become wedged within the body of the windings causing damage to the wire rope. To prevent this keep the wire rope tightly and evenly wound on the drum at all times. Rewind the rope under tension after each use. One method is to attach the hook to a stationary object at the top of a small hill or incline and winch your vehicle up the incline.
- ✗ **DO NOT** allow the motor to overheat. The winch is designed for intermittent use only. During long or heavy pulls the motor will get hot, with its internal parts hotter than the case. To check motor temperature, stop winching and carefully touch the end of the motor. If uncomfortably warm, allow the motor to cool before continuing. Keep engine running to recharge battery during this break.
- 5.2.8. The pull required to start a load moving is often much greater than the pull to keep it moving. Avoid stopping and starting during a pull except when required by motor temperature.
- 5.2.9. Prevent kinks in the cable before they occur, by keeping an even tension on the cable when paying in. (Refer to 5.2.6).
- 5.2.10. Equipping the winch with a roller fairlead (supplied) will substantially reduce wear on the wire rope during angle pulls, because rollers eliminate heavy rubbing and abrasion to the wire rope, see fig.11.
- NOTE:** Never winch your vehicle in gear or in park, which would damage your vehicle's transmission.
Never wrap the wire rope around an object and hook the cable back onto itself, this can cause damage to the object being pulled and kink or fray the wire rope.
Keep hands, clothing, hair and jewellery clear of the drum and cable when winching.
Never use the winch if the cable is frayed, kinked or damaged.
Never allow anyone to stand near the cable, or in line with the cable or behind the winch while it is under power. If the cable should slip or break it can suddenly whip back towards the winch, causing great danger for anyone in the area. Always stand well to the side while winding and use a wire rope dampener.
- ✗ **DO NOT** leave the switch plugged in when the winch is not in use.
CHECK THE WINCH THOROUGHLY AND CAREFULLY BEFORE OPERATING!

fig.11

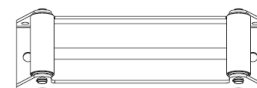

6. MAINTENANCE

- 6.1. It is strongly recommended that the winch is used regularly (once a month). Simply power out 15mtr of cable, free spool 5mtr then power back in. This will keep all the components in good working condition so that the winch can be relied on when needed.



ENVIRONMENT PROTECTION

Recycle unwanted materials instead of disposing of them as waste. All tools, accessories and packaging should be sorted, taken to a recycling centre and disposed of in a manner which is compatible with the environment. When the product becomes completely unserviceable and requires disposal, drain any fluids (if applicable) into approved containers and dispose of the product and fluids according to local regulations.



WEEE REGULATIONS

Dispose of this product at the end of its working life in compliance with the EU Directive on Waste Electrical and Electronic Equipment (WEEE). When the product is no longer required, it must be disposed of in an environmentally protective way. Contact your local solid waste authority for recycling information.

Note: It is our policy to continually improve products and as such we reserve the right to alter data, specifications and component parts without prior notice.

Important: No Liability is accepted for incorrect use of this product.

Warranty: Guarantee is 12 months from purchase date, proof of which is required for any claim.

Sealey Group, Kempson Way, Suffolk Business Park, Bury St Edmunds, Suffolk. IP32 7AR



01284 757500



01284 703534



sales@sealey.co.uk



www.sealey.co.uk